



This data sheet  
interacts with

PSD80 Catalogue



# HepcoMotion®

## No.1 Ballscrew PSD80

The HepcoMotion PSD80 Ballscrew unit is a new addition to the popular PSD80 screw driven linear range. Combining Hepco Herculane® wheel technology with a ballscrew drive, the PSD80 ballscrew unit provides excellent all round performance in a compact and cost effective package.

High precision ballscrews with pitches of 4, 5, 12.7 & 25.4 are available and carriage speeds from zero to 1m/s.

PSD80 ballscrew units are capable of thrust loads of up to 4000N.

The PSD80 beam profile is compatible with the Hepco MCS aluminium frame construction system, and can be assembled into multi-axis systems with Hepco PDU2 and PDU2M units.

### PSD80 Ballscrew Unit

#### Carriage

- High load capacity - up to 500N and 7.5Nm
- Speed - up to 1m/s
- Multiple carriages on a single unit available
- Top plate easily removed & machined.

#### Steel Ballscrew

- Smooth, strong & precise.  
Available in leads of 4, 5, 12.7 & 25.4mm with right handed threads, and 5mm only with left handed threads.

#### Stainless Steel Cover

- Effectively seals the unit from debris.

#### Internal Buffers

- End of stroke protection at both ends.

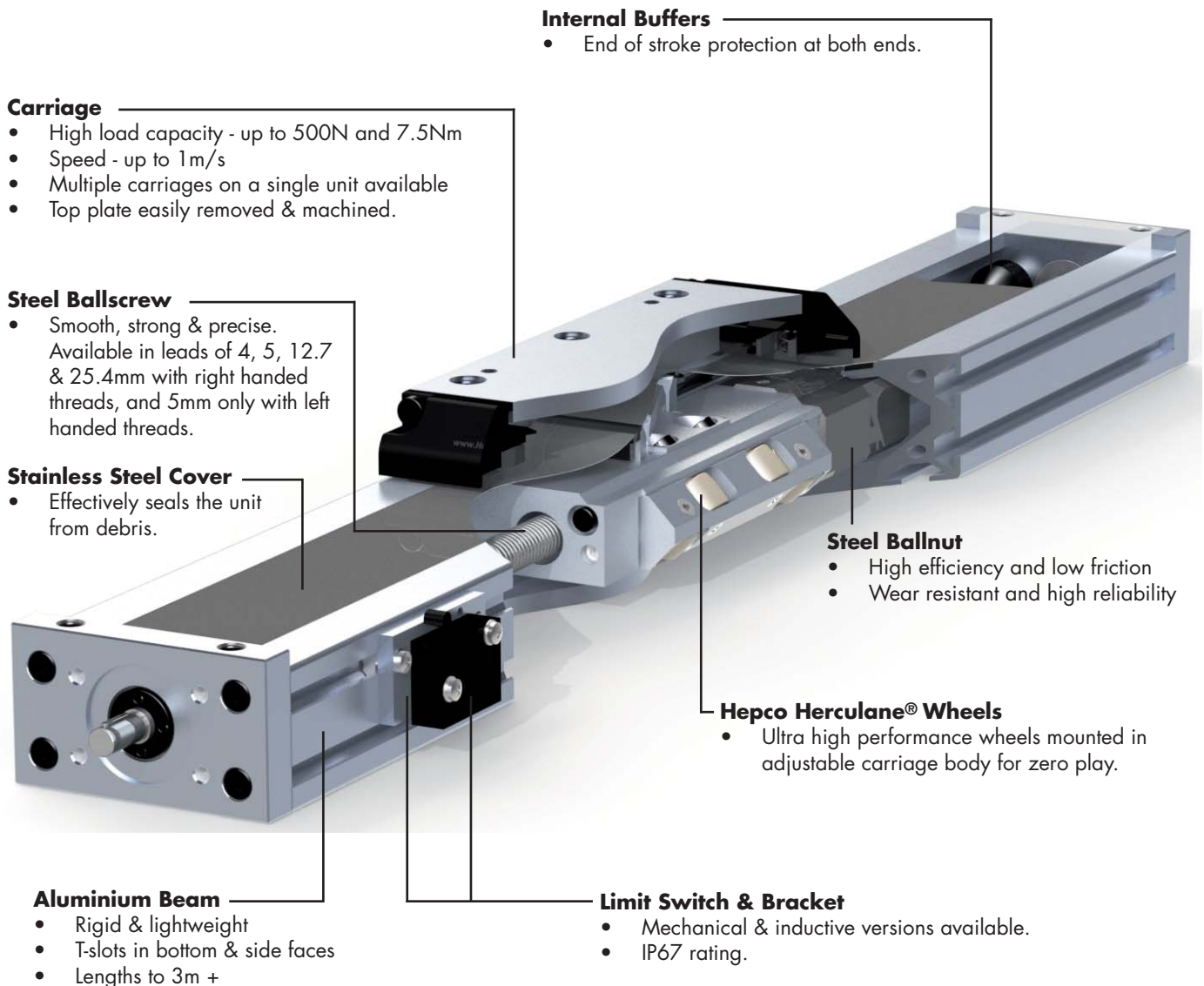

#### Steel Ballnut

- High efficiency and low friction
- Wear resistant and high reliability

#### Hepco Herculane® Wheels

- Ultra high performance wheels mounted in adjustable carriage body for zero play.

#### Aluminium Beam

- Rigid & lightweight
- T-slots in bottom & side faces
- Lengths to 3m +

#### Limit Switch & Bracket

- Mechanical & inductive versions available.
- IP67 rating.

# Data & Dimensions - Ballscrew Units

## PSD80 Closed Slave Unit

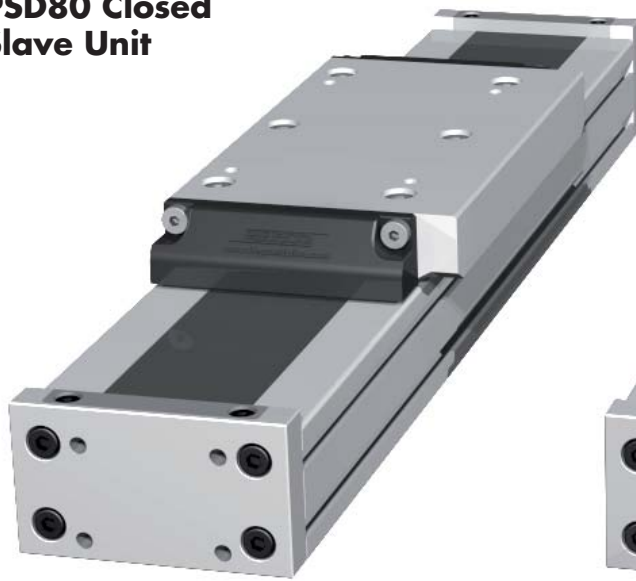

## Screw Driven PSD80 Closed Unit

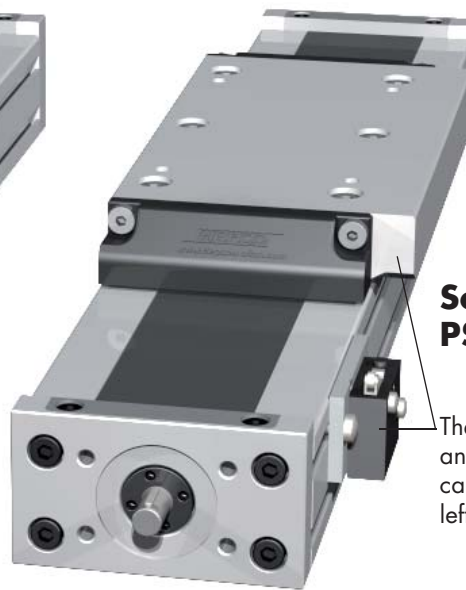

The position of the switches and the switch cam on the carriage are easily reversed left to right.

The main dimensions of the PSD80 ballscrew unit are shown in the drawing below. Further details can be obtained from the 2D and 3D CAD files, available from [www.HepcoMotion.com](http://www.HepcoMotion.com).

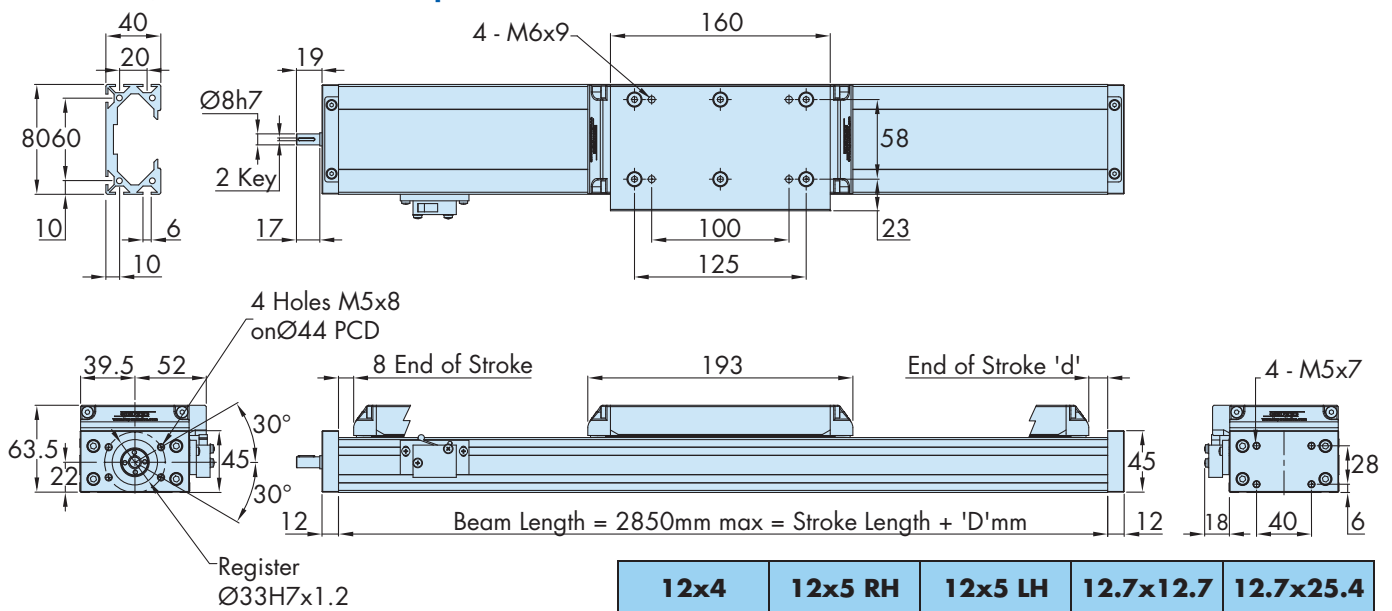

	12x4	12x5 RH	12x5 LH	12.7x12.7	12.7x25.4
<b>d</b>	23	23	23	42	27
<b>D</b>	224	224	224	243	228

PSD80 ballscrew units are covered by a stainless steel band with contacting seals on the ends and sides of the carriage. This arrangement provides good protection for the unit's moving parts against ingress of debris.

The above drawing shows a unit with a single carriage, but it is also possible to specify units with one or more additional carriages. The usual arrangement for such systems is for just one carriage to have a drive nut, but it is also possible (on request) to offer units in which multiple carriages are driven by the same screw. For units with more than one carriage, the carriage centres should be separated by at least 270mm to allow the cover to function correctly. Contact Hepco's Technical Department for full details.

The length of screw driven PSD80 units is limited by the available screw length. Units with beams up to 2850mm long can be made, but in many cases the performance of the screw (due to whipping & buckling) will limit the practicable length to between 1 and 1.5m. These aspects of performance are calculated 5. If units have additional carriages, then it is possible to increase the unit length before encountering dynamic problems. Contact Hepco for details.

Slave units may be ordered with beam lengths up to 6m in one piece. Slave units are normally supplied with a fitted spacer so that the stroke length and buffer positions match driven units of the same length. This spacer can be deleted if not required 6.

Both driven and slave units have internal buffers. It is usual practice with driven systems to stop motion some distance before the buffers are contacted.

# Data & Dimensions - Ballscrew Double Acting Units

## PSD80 Ballscrew Double Acting Unit

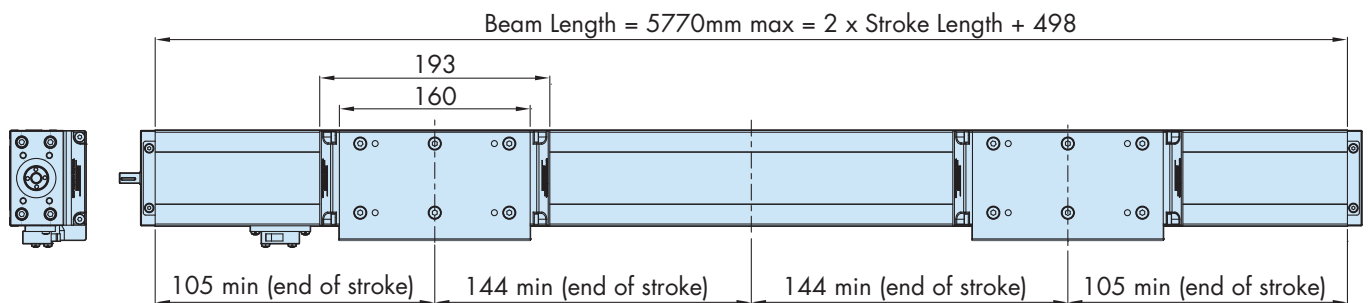

All other dimensions of double acting PSD80 units are the same as the closed units shown 2.

PSD80 double acting units have two (or more) carriages whose movements are symmetrical about the middle of the beam, this motion being achieved by using linked left and right hand threaded screws. The units may be ordered with 5mm screw leads only. They share the same major parts, and have the same benefits as other PSD80 units, and are available in closed formats.

The unit shown above has two carriages, but it is common to have additional slave carriages, particularly if the items to be moved are large (see application example 3 main PSD80 catalogue).

PSD80 double acting units are suitable in numerous applications including mechanical handling, automation and as an actuator for sliding doors (see application example 3 main PSD80 catalogue).

Units can be made with beams up to 5770mm long, but in many cases the performance of the screw (due to whipping & buckling) will limit the practicable length to between 2 and 3m. These aspects of performance are calculated 5. For units which have additional carriages, it is possible to extend the length of the beams while still avoiding dynamic problems with the screws. Please contact Hepco for full details.

PSD80 units have a beam profile with 6mm wide T-slots which are compatible with profiles, T-nuts, covers and brackets from the HepcoMotion MCS aluminium frame construction system. The same T-slot size and spacing is also used on companion products PDU2 and PDU2M.

# Calculations & Performance

## Carriage Service Interval Calculation

After very long service, slight play in the carriage may develop due to wheel wear. This can be corrected by re-adjusting the carriage, which will return the unit to its original condition. Adjustment is quick and simple and may be repeated several times. The table shows the maximum carriage loading, and the calculation below determines the service interval.

Hepco will provide more data and calculations for your application, on request.

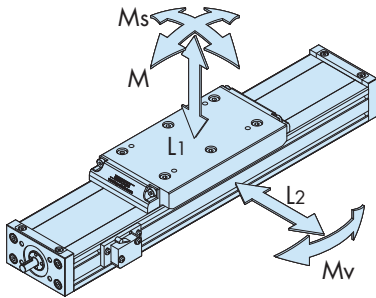

Carriage Load Capacity				
L1	L2	Ms	Mv	M
500N	500N	7.5Nm	14Nm	14Nm

To determine service interval, first calculate the load factor L<sub>F</sub> using the equation below.

$$L_F = \frac{L_1}{L_{1(max)}} + \frac{L_2}{L_{2(max)}} + \frac{M_s}{M_{s(max)}} + \frac{M_v}{M_{v(max)}} + \frac{M}{M_{(max)}} \leq 1$$

$$\text{Service Interval (km)} = \frac{5000}{(0.25 + 0.75 \times L_F)}$$

Note: carriage life will be several times this service interval

PSD80 Unit Weights (kg)							
Standard Units (1 carriage)		Slave Units (1 carriage)		Double Acting Units (2 carriages)		Carriage Weights	
Closed	Open	Closed	Open	Closed	Open	Closed	Open
3.5 x L + 1.7	3.4 x L + 1.0	2.9 x L + 1.4	2.8 x L + 0.7	3.5 x L + 3.2	3.4 x L + 1.9	1.1	0.5

The weight of a unit is calculated using the formulae in the table above, where L is the beam length in m. For units with extra carriages, add the weight per carriage shown in the table above. This data will also allow the calculation of the mass of the moving parts.

## Ballscrew Life

The table below provides a summary of average trust load against nominal total linear travel capacity of the ballscrew.

Pitch	Average Trust Load (N)				
	500km	1000km	2500km	5000km	10000km
4mm	1100	873	643	511	405
5mm	1422	1129	832	660	524
12.7mm	2352	1866	1375	1092	866
25.4mm	852	676	498	395	314

## Beam Deflection Calculations & Data

The deflection of a PSD80 under load follows conventional beam calculations.

For example, the deflection of a PSD80 unit L (mm) long, simply supported at the ends and subject to a central load F (N) is:

$$\text{Deflection (mm)} = \frac{F \times L^3}{48 \times E \times I}$$

Where E is the young's modulus of aluminium alloy (= 7x10<sup>4</sup> N/mm<sup>2</sup>) and I is the second moment of area of the PSD80 beam section (= 2.0x10<sup>5</sup> mm<sup>4</sup> for L<sub>1</sub> loading direction and 7.8x10<sup>5</sup> mm<sup>4</sup> for L<sub>2</sub> loading direction).

**Example:** in the case of a simply supported PSD80 beam 1000mm between supports, and subject to a central L<sub>1</sub> loading of 150N, the deflection at the centre of the span will be 0.22mm.

## Drive Data & Calculations

The torque (T in Nm) required to generate a given thrust is determined by the magnitude of the linear force (in N) required, the force coefficient (C<sub>f</sub>) and composite drag (D<sub>c</sub>) of the PSD80 unit.

PSD80 Ballscrew Force Coefficient C <sub>f</sub>				
Screw Lead /mm	4	5	12.7	25.4
Force Coefficient C <sub>f</sub>	1413	1130	445	223

$$\text{Linear Force (N)} = C_f \times T - D_c$$

PSD80 Composite Drag D <sub>c</sub>	
Closed Units	10+5L <sub>F</sub>

$$\text{Torque (Nm)} = \frac{\text{Linear Force} + D_c}{C_f}$$

The above equation gives the linear force developed by a typical system in typical conditions, but there will be some variation. It is recommended to select motors which have significantly more than the minimum torque, to ensure performance and reliability.

Applications in which the applied load is in the opposite direction (i.e. when the load is trying to back-drive the unit) will demand less torque. Please contact Hepco for calculation assistance in these cases.

# Calculations & Performance

## Rotary - Linear Speed Equivalence

Motor Speed rpm	100				500				1000				2000			
Screw Lead mm	4	5	12.7	25.4	4	5	12.7	25.4	4	5	12.7	25.4	4	5	12.7	25.4
Linear Speed m/s	0.007	0.008	0.021	0.042	0.033	0.042	0.106	0.212	0.067	0.083	0.212	0.423	0.133	0.167	0.423	0.847

## Thrust Load Performance

The amount of thrust that a PSD80 ballscrew unit can produce depends upon the screw lead type, the speed of the system, and the life required (see  5). Please contact Hepco for advice on suitability for your duty.

The table below provides the thrust capacities of each nut type and typical thrust capacities of the PSD80 ballscrew unit. In many applications, the capacity of the nut itself does not limit the maximum thrust load of the PSD80 ballscrew unit. Please also refer to the critical speed and buckling load graphs. Critical buckling loads will determine the maximum thrust for the majority of systems.

	Ballnut Static Thrust Load Capacity (N)	Ballnut Dynamic Thrust Capacity (N)	Thrust Capacity for a typical 1 metre long system (N)
4mm lead	11000	5500	490
5mm lead	12000	6600	440
12.7mm lead	15500	8000	620
25.4mm lead	4500	2300	690

## Screw Critical Speed

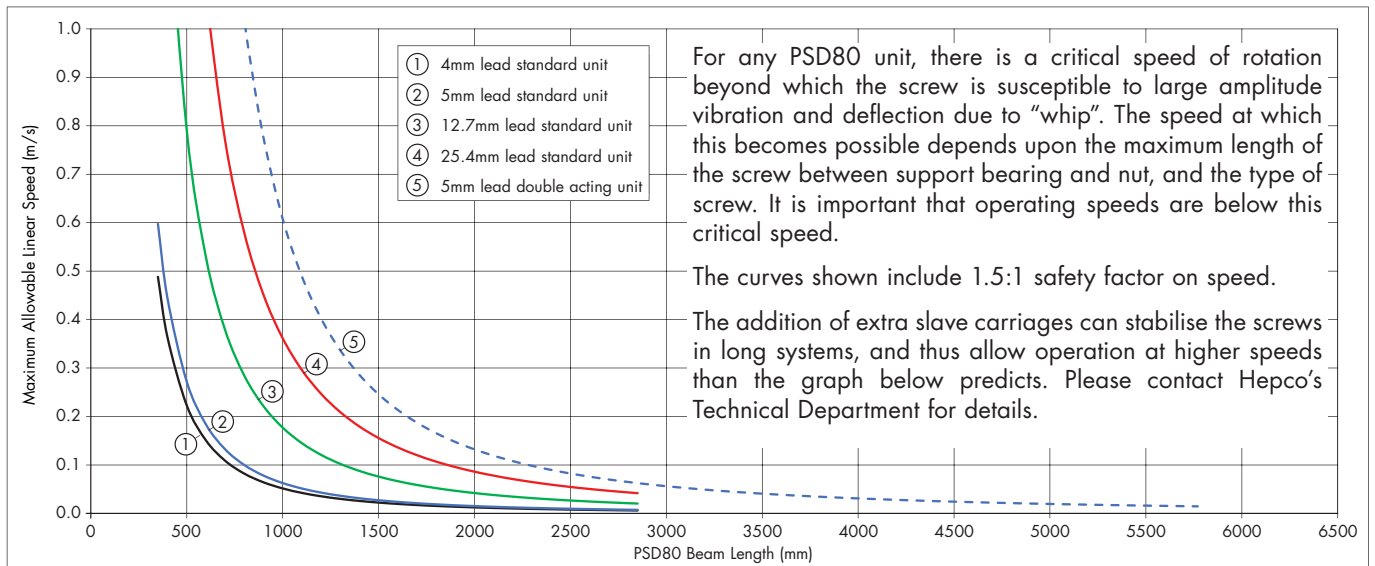

## Screw Buckling Load

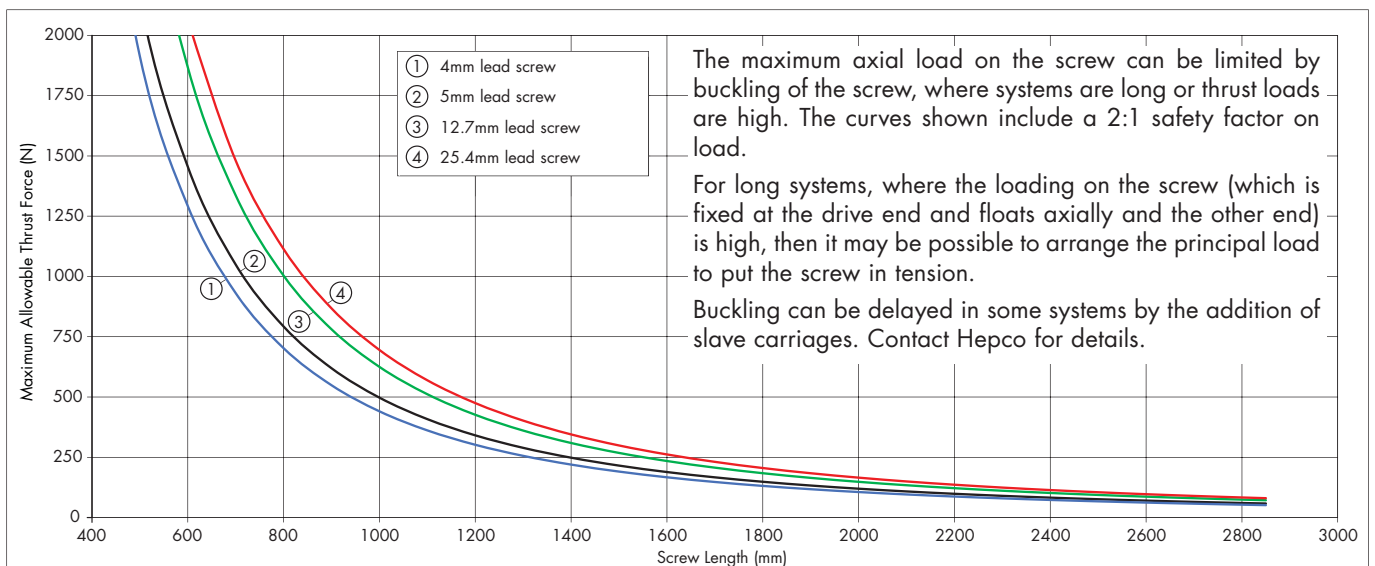

# How to Order

This ordering information is given to assist communication, but we recommend that you discuss the application with Hepco first so that we can help to specify the best unit for your needs.

## Main Unit

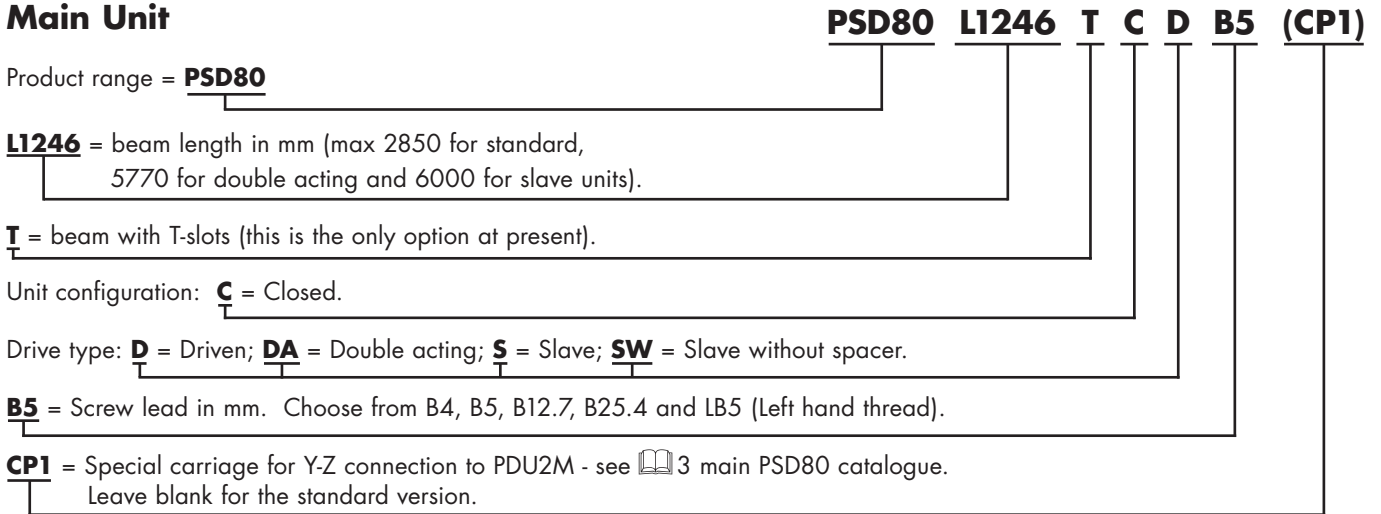

## Additional Carriages

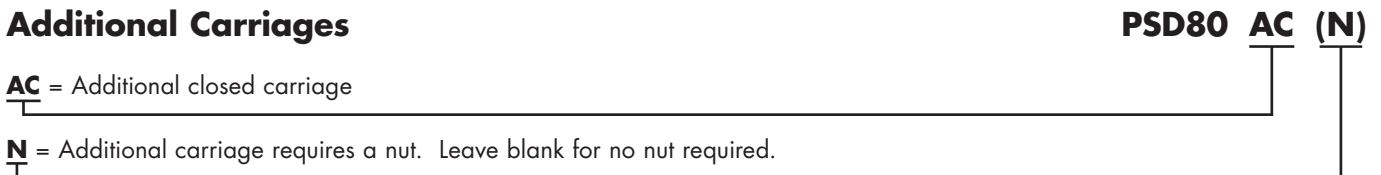

To specify additional slave carriage(s) on a PSD80 unit, simply put the quantity and the relevant part number on the order after the part number for the main PSD80 unit, and state where the carriages should be fitted (i.e. at the driven or non-driven end. If the N option is specified, then the carriage spacing centre distances must also be stated).

## Ancillary Components

Limit switch assembly (includes switch, bracket & fixings) = PDU2-V3SWA-M (mechanical), PDU2-V3SWA-I (inductive).

T-nuts: M3 = 1-242-1022; M4 = 1-242-1023.

T-slot cover (supplied fitted in each of the T-slots) = 1-242-1037.

## Motor Connection Kits

These include the flange tube, motor flange, coupling components and all fasteners required to connect the customer's motor to a PSD80 unit.

The following standard kits are available from stock:

**PSD80MCK-NEMA23** Suits 23 frame stepper motors

**PSD80MCK-NEMA34** Suits 34 frame stepper motors

**PSD80MCK-IEC56** Suits 56 frame induction motors

**PSD80MCK-IEC63** Suits 63 frame induction motors

**PSD80MCK-IEC71** Suits 71 frame induction motors

When ordering these motor kits please state the motor shaft diameter, length and key details, as these may vary between manufacturers.

Hepco will make flanges to fit any motor type, on request.

Hepco will supply units with fitted motors and drives, on request.

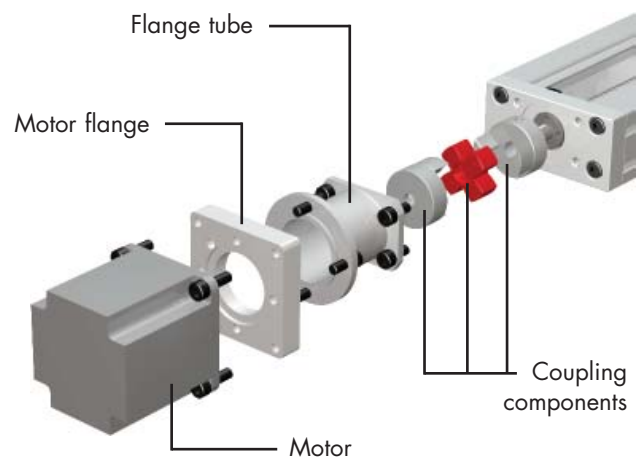

HepcoMotion®, Lower Moor Business Park,  
Tiverton Way, Tiverton, Devon, England EX16 6TG

Tel: +44 (0) 1884 257000

Fax: +44 (0) 1884 243500

E-mail: sales@hepcotion.com

[www.HepcoMotion.com](http://www.HepcoMotion.com)

